

Highly-dynamic laser technology for ultra-fast and precise micro texturing of three-dimensional surfaces

Florian Rößler¹, Christian Mikley², André Streek^{1,3}

¹ MOEWE Optical Solutions GmbH, Mittweida, Deutschland

² ACSYS Lasertechnik GmbH, Mittweida, Deutschland

³ Laserinstitut Hochschule Mittweida, Mittweida, Deutschland

Laser engraving requires a precise ablation per pulse through all layers of a depth map. To transform this process towards areas of a square meter and more within an acceptable time, needs high-power ultra-short pulsed lasers for the precision and a high scan speed for the beam distribution. Scan speeds in the range of several 100 m/s can be achieved with a polygon scanner. In this work, a polygon scanner has been utilized within a roll-engraving machine to treat an 800 x 220 mm² (L x Dia) roll with 0.55 m² in a laser engraving process. The machine setup, the processing strategy and the data handling has been investigated and result in an efficient large area process. Pre-tests were performed with a multi-MHz-frequency nanosecond-pulsed laser, to investigate the processing strategy. A method to overcome the duty cycle of the polygon scanner was found in the synchronization of two polygons, enabling the use on a single laser source in a time-sharing concept. The throughput and the utilization of the laser source can be increased by the factor of two

1. Introduction

Roll engraving with a laser can enable high resolution texturing with a non-contact tool and increase the fabrication speed. With pulsed lasers, it is necessarily having a pulse-to-pulse distance in the order of magnitude of the pulse diameter to avoid strong pulse overlap, which is associated with thermal damaging.[1,2] Polygon mirror scanners has shown the capability to deflect lasers beams with ultra-high speeds of several 100 m/s and thus, to distribute high laser powers on the target material.[3] Hence, pulses in the MHz-range can be separated from each other or be applied with a small pulse overlap only. The application of high repetition rates reduces the processing time in combination with the fast beam deflection.

Former engraving experiments with nanosecond pulsed lasers and polygon scanners, show very high ablation depth per pulse and also impressive overall engraving depth. However, the surface quality is bad and shows strong roughness in the range of the engraving depth. This indicates, that a big amount of ablated material, especially the molten material, is just pushed from the ablation zone in neighbored regions but not finally extracted from the working area. Thus, the quality must become better. [4]

The utilization of USP lasers has the advantage to ablate a well controllable volume per pulse with small ablation depth. To increase the overall ablation rate, pulse repetition rates up to 50 MHz are state of the art, and thus the repetition rate is much higher compared to nanosecond pulsed system. Additionally, the "cold ablation" also reduces the melt involved in the process nearly complete compared to SP or CW processes, which not only makes the process more controllable, it reduces also the redeposition of material next to the ablation area. This

allows a well-controllable process and engrave very precise with resolutions in the single μm scale. [5,6]

In this work, a fully integrated roll engraving machine is set-up and utilizing a polygon scanner to treat large areas. Pre-tests and system investigations were performed with a nanosecond pulsed laser.

2. Experimental

For the roll engraving, a polygon scanner (PM-series, MOEWE) was mounted on a portal axis for lateral movement along the roll axis, while the roll itself can be moved perpendicular to the axis and can turn around its axis as visible in Fig. 1.

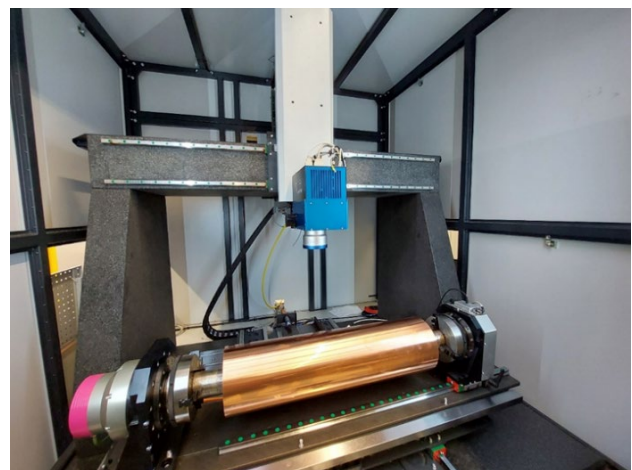

Fig. 1: Roll engraving machine with polygon scanner, copper roll and fiber laser. On the roll, a "puzzle-like" pattern is shown fabricated for test purpose in a black paint with the polygon scanner and a nanosecond pulsed laser.

The roll has a size of 220 x 800 mm and is made of copper. For the first tests, a nanosecond pulsed fiber laser

(200 W MOPA) was used to investigate the process strategy, the laser alignment and the stitching alignment. To avoid material waste, black color was painted to the copper roll and was selectively removed by the laser.

The polygon scanner deflects the laser beam with up to 100 m/s in a line parallel to the roll axis and the roll turns to feed the surface into the scan field. Thus, a ring segments are processed one after another.

3. Results and Discussion

The engraving system consist of several individual components that must play together for a successful laser process. First of all, the beam deflection and the machine movement must act together. A linear axis moves the scanner in parallel to the cylinder axis, while the roll rotates during the process. Here it is very important, that the coordinate systems of the axis and the scanner are the calibrated to each other.

Especially the optical distortions of the F-Theta lens can cause position displacements. Therefore, a scan field of 100 x 100 mm² was shot on a sensitive material including 5x5 position marks (25 mm spacing). The position error was measured translated in a correction matrix of 256 x 256 positions. This matrix can be used in the scanner to correct the scan field distortions in slow axis by slightly adjusting the galvo position depending on the current position. In fast axis, the laser trigger signal is temporally adjusted to fit the rising edge of the laser trigger to the real position respecting the distortions. At this time, this is performed with a polynomic correction of second order. A correction with matrix is here also an option in the future. With this distortion methods, a scan length of 100 mm was adjusted to the machine coordinates, which is at the same time the stitching size. Thus, a gap or overlap between stitched ring segments was avoided.

During the process, the FPGA based scanner logic contains the processing information, deflects the beam and switches the laser accordingly. An overview of all signals and interfaces is presented in Fig. 2.

For accurate positioning, the scanner needs to know the current machine position all the time and must react to machine movement. This requires a real time communication, which is realized with an interface for up to three axes. This interface does not use any communication protocol but reads directly the incremental encoder signals from the axis position detector. The use of this electric signal allows the scanner logic to the position changes.

Inside the engraving machine, the scanner is a device, that must be able to exchange some status information and get also some external signals from the machine controller. Therefore, a general-purpose interface (GPIO) was integrated in the scanner, to tell the machine some states like system ready or laser process running. In the other direction, a hardware start / stop of the process is able due to electric impulses.

Additionally, a programming interface was introduced, which allow a command-based change of scanner parameters from an external device or application.

The three interfaces allow machine communication, position correlation and configuration changes, which enables full machine integration of the polygon scanner within the operation environment of the machine.

The shape of the roll indicates a rotation to feed the material into the working area, while the polygon scanner is used to distribute the laser radiation in a line parallel to the roll axis. The used f-theta lens with a focal length of 255 mm allows a processing length of this line up to 140 mm or a square of approximately 100 x 100 mm². Due to the curved surface a lateral positioning of the scanned line results in a defocusing, that only a small range of 2.5 mm around the top position was used. The small scan field perpendicular to the fast scanned line is necessary to follow the moving substrate and to have a spare in case a line was skipped, due to any uncertainty. To force the scanner into a nominal working position on top of the roll, the scan field can be defined asymmetric, with only 0.5 mm against (or even smaller) the feed and with 2 mm with the feed. Typically, a line is treated and

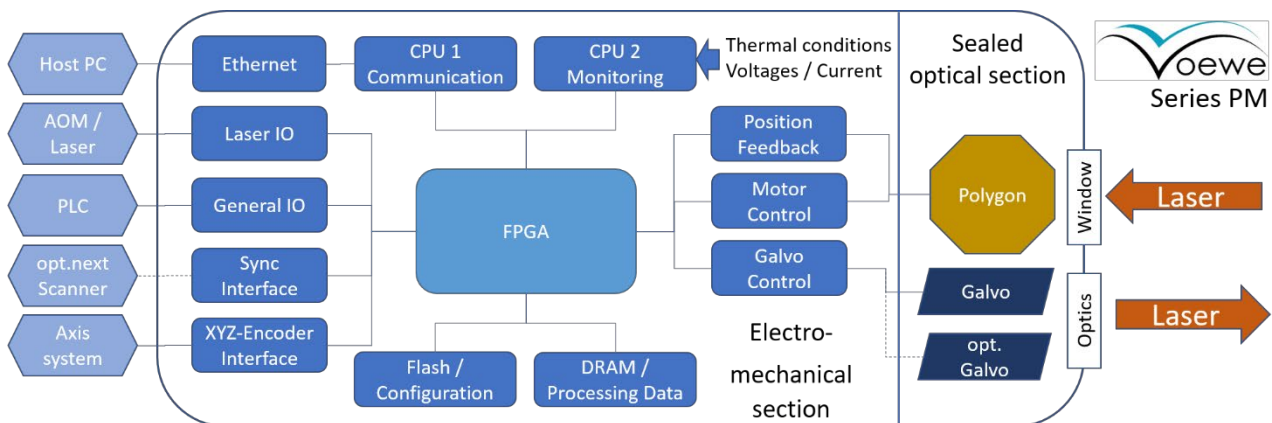

Figure 2: FPGA based data and signal processing inside the scanner and interfaces to the machine environment.

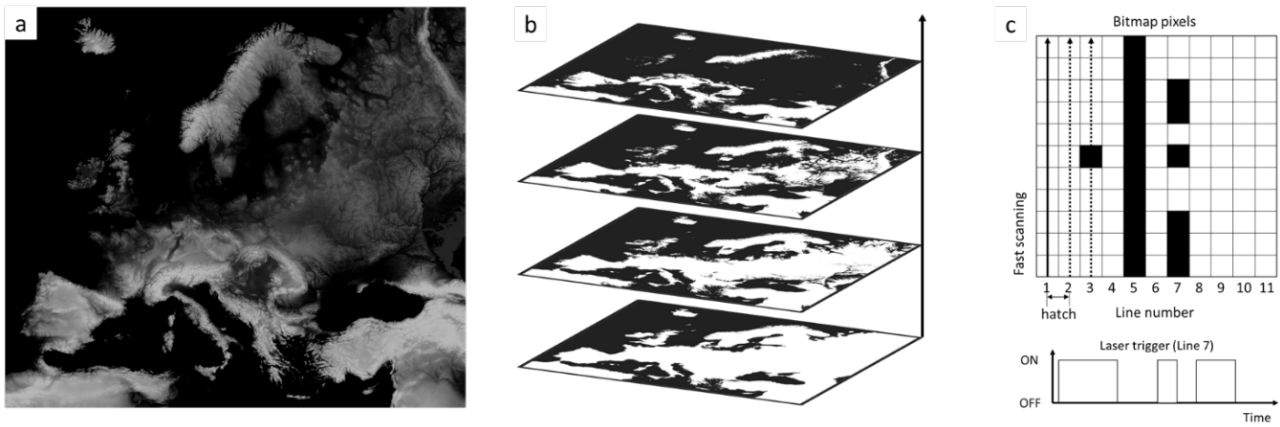

Figure 3: (a) 8-bit depth map of Europe with sea level in black (bit value 0) and mountains gray / white (up to 187), (b) illustration of black / white bitmaps per depth level as done in the FPGA logic of the polygon mirror scanner and (c) laser switching per scanned line according to the bitmap value.

the galvanometer axis follows the feed direction during the polygon is marking the line. After the line is finished the scanner jump to the position of the next line. If the feed rate is smaller or equal to the maximum feed rate, the scanner will wait at the beginning of the scan field (e.g. -0.5 mm) until the next line is feed into the scan field. The maximum possible feed rate is depending on the line frequency of the scanner and the line spacing (hatch) between neighbored lines. An exceeding feed rate causes, that the scanner is not able to treat all lines. After finishing one line, the next line is already in the scan field and with every line mismatch increases and the scanner needs to skip lines.

The start of the process is coupled to the index of the rotation encoder (zero position). After one full stripe is processed, the scanner is moved into the next position and the next stripe will be done.

The working principle of the engraving process with the polygon scanner was demonstrated in the past. Therefore a grayscale image was internally sliced in black and white images and then the laser was triggered according to the pixels as shown in Fig. 3.

For the large size of the roll cylinder and a target resolution of 5-20 μm , the data size of several 10 GB exceeds the memory of the scanner. Therefore, a pre-processing is necessary. In this case, a slicing and cutting in the strip-wise sub-images is a useful way to reduce the data size. The scanner will see only black and white images. To avoid intermediate loading times, a continuous loading algorithm was developed, that replaces already treated lines in the internal memory by loading new lines from a hard drive on an external PC. First tests of the full integrated machine were done with a nanosecond pulsed laser and show a full treated layer of black paint on the copper.

Although the polygon scanner can distribute the laser radiation ultra-fast and can therefore enable significantly higher throughput than conventional beam deflection systems, there is a limitation on the utilization in the optical concept of the scanner. During the operation of a

polygon scanner, the laser beam must be switched off at the edge of the facet. Depending on the beam diameter and the facet size, the relation of operating and waiting time is defined. This duty cycle is between 40 and 60 % in the optical concept of the used polygon scanner. Especially on high power laser sources, which are very expensive at the same time, the low utilization can an economic barrier. An increase of the duty cycle by adapting the geometry is not suitable due to the large diameter and mass, which would result from an enlarged polygon mirror. Hence, a utilization of two scanner devices at a single laser source can increase the utilization of the laser and result in a doubled throughput. A schematic is shown in Fig. 4.

For the synchronization of two scanners, it is necessary, that both polygon mirrors run at the exactly same speed and that they have a defined angular offset to each other. In the case of two scanners, it is 22.5°. Additionally, a fast beam switch is required to distribute the initial laser beam to the scanner devices.

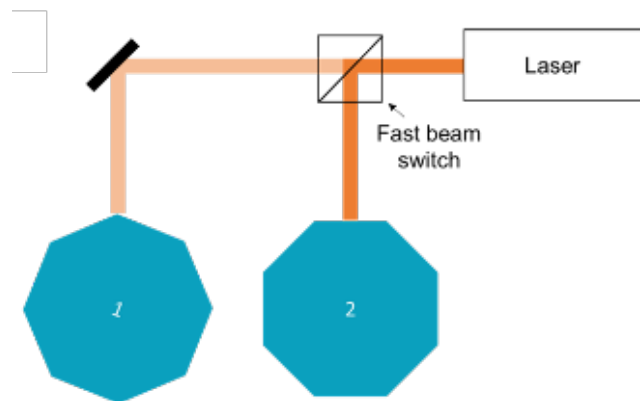

Figure 4: Beam sharing of a single laser beam to two scanners. One scanner is working due the other is in the facet change.

The motor of the polygon scanner is controlled by a position clock signal. By sharing this signal to the motor driver to a second device, both motors can run following the same clock. A new interface is introduced to share this signal. Two plugs where placed, in order to use one plug for clock transmitting and one for reception. This

could be used to build up a chain of following devices in the future.

The synchronization could be enabled successfully and from the company edgewave, a USP-laser with two fast switchable beam outputs was realized. Thus, the fast beam switch is already part of the laser source. In a laboratory setup, the synchronization could be verified practically, by treating different materials with the synchronized scanners.

4. Conclusion

A new machining concept for roll engraving was presented using a fast beam deflection by a polygon mirror scanner. This allows the utilization of high repetition rate ultra-short pulse lasers for engraving with high resolution. The position synchronization between roll movement and laser scanner as well as the electric communication were designed and tested under industrial environment. Also the layer-wise processing strategy was investigated and demonstrated with a seamless stitching

between the laser ablated ring segments. Finally, a strategy for large data handling was investigated and shown under practical conditions.

To increase the throughput further, a synchronization technology of two polygon scanners was developed and investigated. Thus, two scanners with an individual duty cycle of 50% or less can be utilized on a single laser source. Hence, the utilization of the laser source raised close to full load and the throughput is doubled.

Acknowledgement

The authors thank for the funding of the German federal ministry of research and education (BMBF) in the program "WIR! – GRAVOmer" supporting under the grant numbers 03WIR2009A, 03WIR2009B, 03WIR2009C in the project "HoLuMi-3D"

Literature

- [1] R. Weber, T. Graf, P. Berger, V. Onuseit, M. Wiedenmann, C. Freitag and A. Feuer (2014): Heat accumulation during pulsed laser materials processing, in: *Optics Express*, 22, 11312
- [2] J. Finger and M. Reininghaus (2014): Effect of pulse to pulse interactions on ultra-short pulse laser drilling of steel with repetition rates up to 10 MHz, in: *Optics Express* 22, 18790
- [3] A. Streek, M. Lee (2017): Ultrafast Material Processing with High-Brightness Fiber Lasers: Increasing process speed with high power single-mode fiber lasers and ultrafast polygon scanner, in: *Laser Technik Journal* 14 (4), 22-25
- [4] F. Rößler, M.Müller, A. Streek (2021): High-power nanosecond pulsed laser engraving with an ultra-high speed polygon mirror scanner, in: *Proceedings of 12th Mittweidaer Lasertagung*, 66-68
- [5] B. Jaeggia, B. Neuenschwander, T. Meier, M. Zimmermann, G. Hennig (2013): High precision surface structuring with ultra-short laser pulses and synchronized mechanical axes, in: *Physics Procedia* 41, 319-326
- [6] D.J. Förster, B. Jäggi, A. Michalowski, B. Neuenschwander (2021): Review on Experimental and Theoretical Investigations of Ultra-Short Pulsed Laser Ablation of Metals with Burst Pulses, in: *Materials* 14, 3331.